

*Here is a set of
Project Plans
from*



Copyright © 2004

All Rights Reserved

FREE • FORM COFFEE TABLE

SWEDISH MODERN

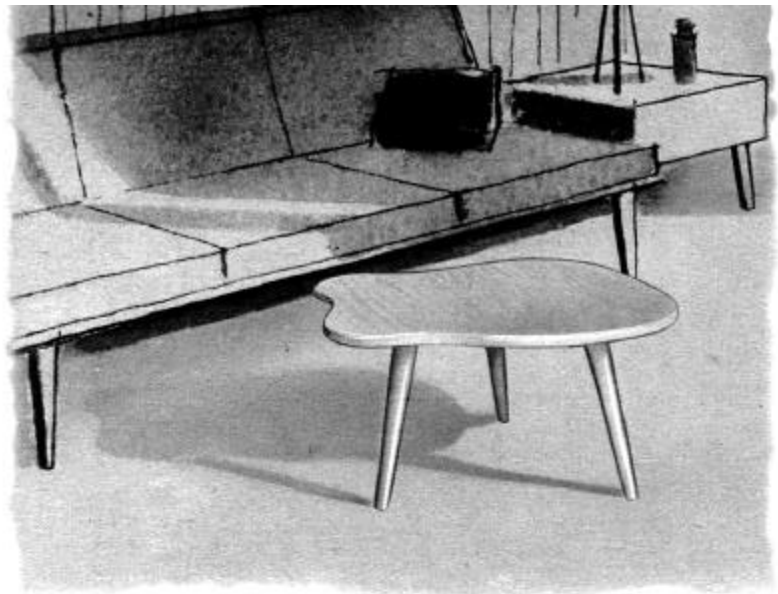

1

Designed in the contemporary Swedish modern style so popular with home decorators today, this coffee table can be easily made in a few hours.

Knotty pine is the prevalent stock used for this type of furniture. However, good results can be obtained with many kinds of stock. You may even want to use scrap stock you have on hand.

The table top outline is drawn on glued up stock using the squares method, Fig. No. 1, and cut out on the band saw. The edge of the top is moulded on the spindle shaper with the No. D-103 three-lip cutter, Fig. No. 2 and Photo No. 4.

Legs are taper turned as shown in Fig. No. 3 and Photo No. 2. The leg tops are turned with a tenon

to fit in the drilled holes in the leg cleats. The two leg cleat (A) has holes drilled at compound angles to give an outward splay to the legs. The drilling operation is done on the drill press with the use of a jig, and with the drill press table tilted 15°, Photo No. 3. If your drill press table does not tilt, make a hinged table as shown in Fig. No. 4. The single leg cleat has a hole bored at 15° with the stock set parallel with the front edge of the drill press table, Fig. 5.

The popular finish for this type of furniture is natural. A coat of white shellac, followed with a rubbed effect varnish will give a fine smooth satin finish.

BILL OF MATERIALS

No. Req'd.	Name	Size
1	Top.....	¾x27x32"
3	Legs.....	1¾x1¾x16"
1	Cleat (A).....	1¾x3½x20"
1	Cleat (B).....	1¾x3½x17"
4	Flat Head Screws.....	# 9-1½"

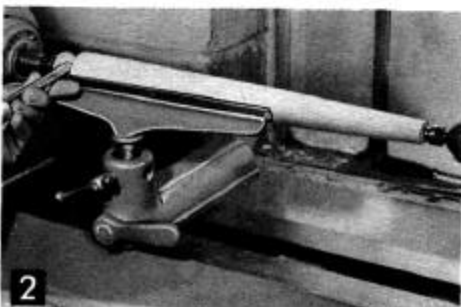

The legs are tapered on the lathe with the tenon made to fit the 1-1/4" hole in the leg cleats.



1-1/4" holes are bored on the drill press using a multi-spur bit. The jig board (Fig. 4) is mounted to the drill press table with C-clamps and the drill press table tilted 15 degrees.



The table top edge is free hand shaped on the spindle shaper with the No. D-103 three-lip cutter. The start of the moulding is made against the taper starting pin.

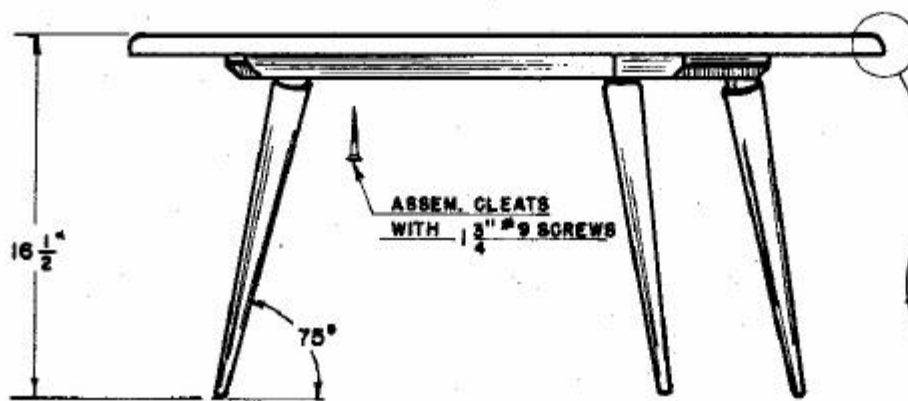
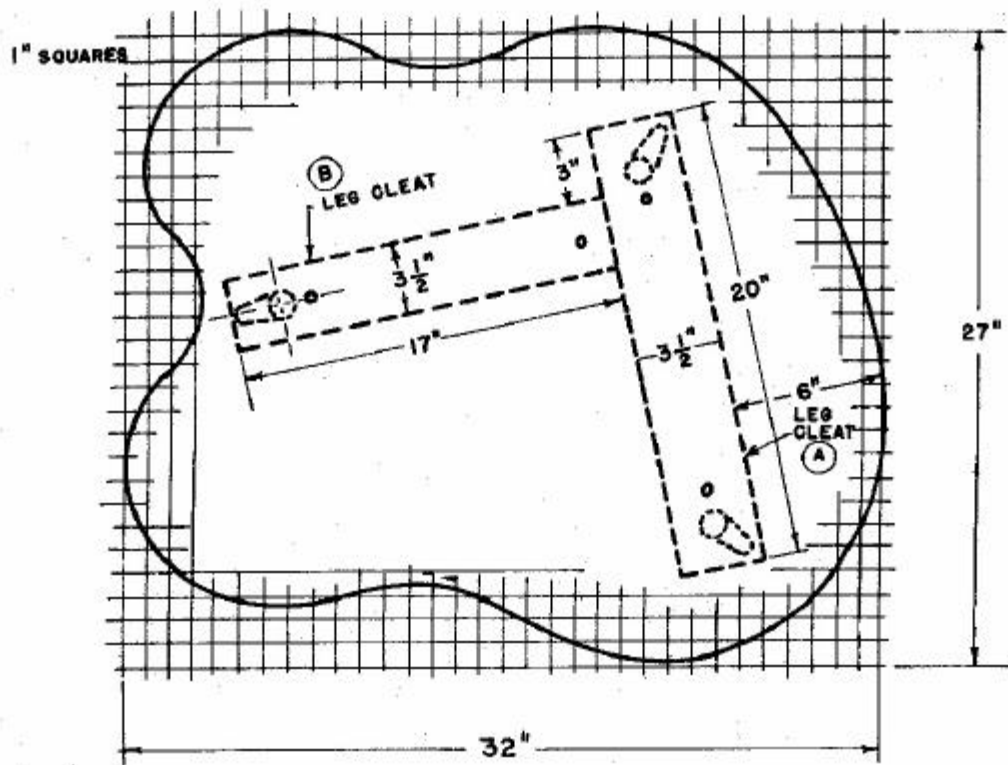

FIG. 1

FIG. 2

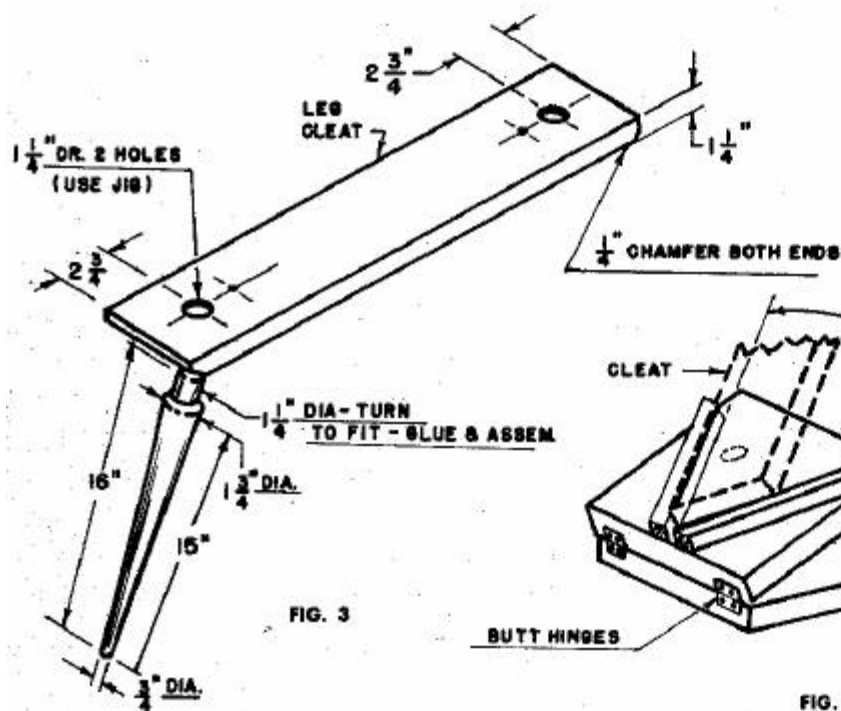

FIG. 3

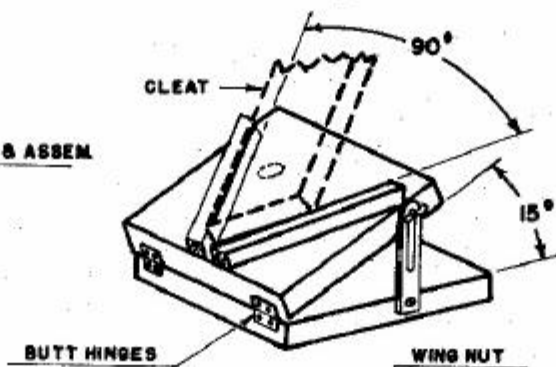

FIG. 4

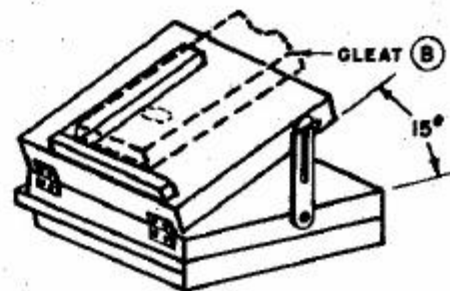
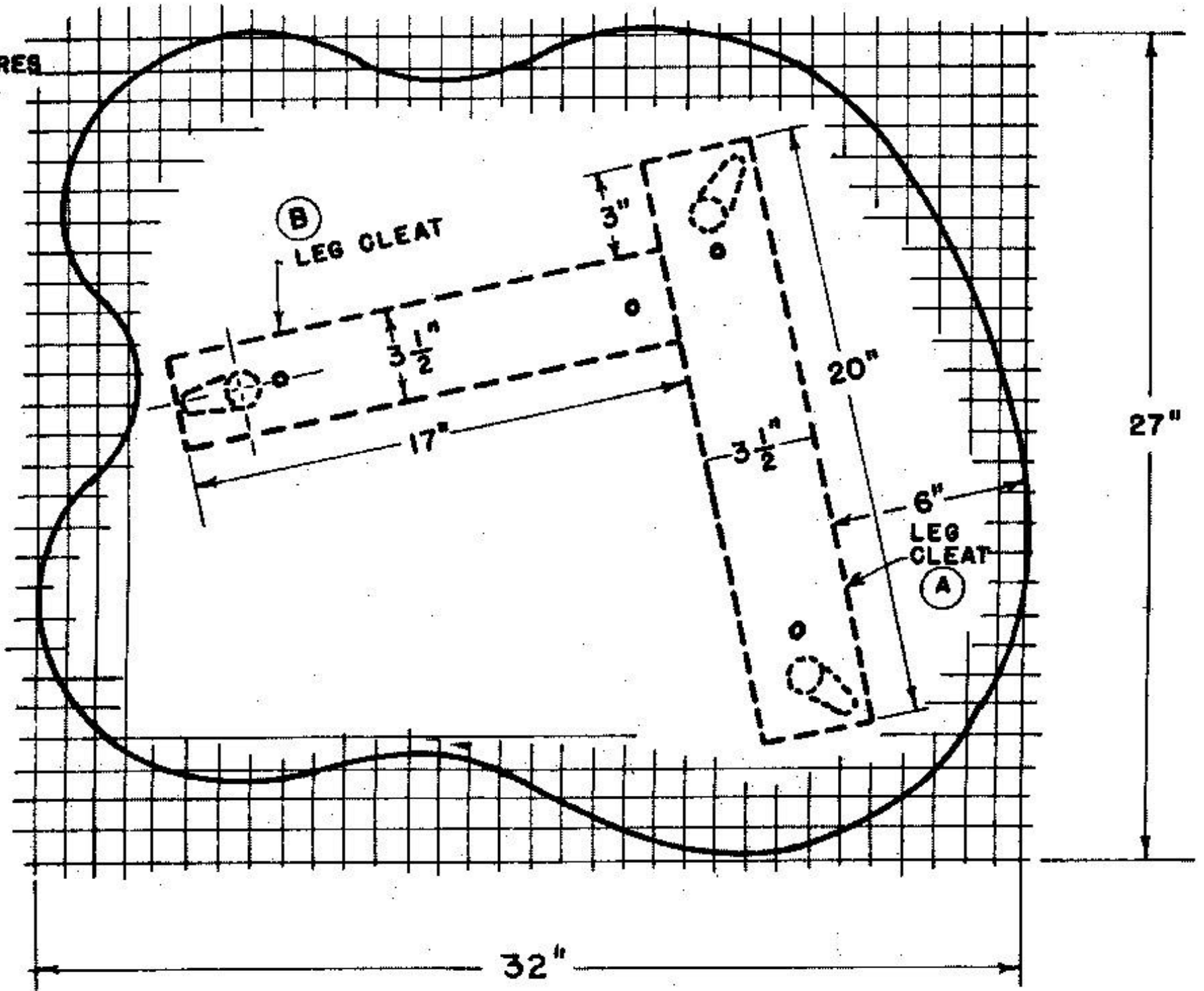

FIG. 5

1" SQUARES



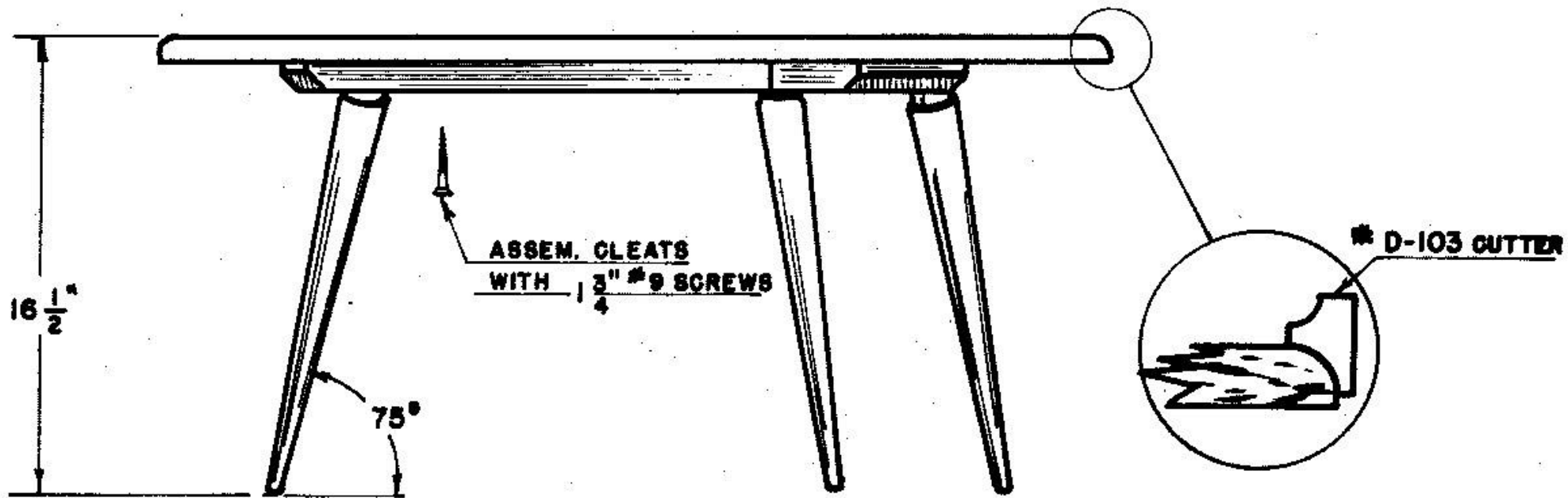

FIG. 1

FIG. 2

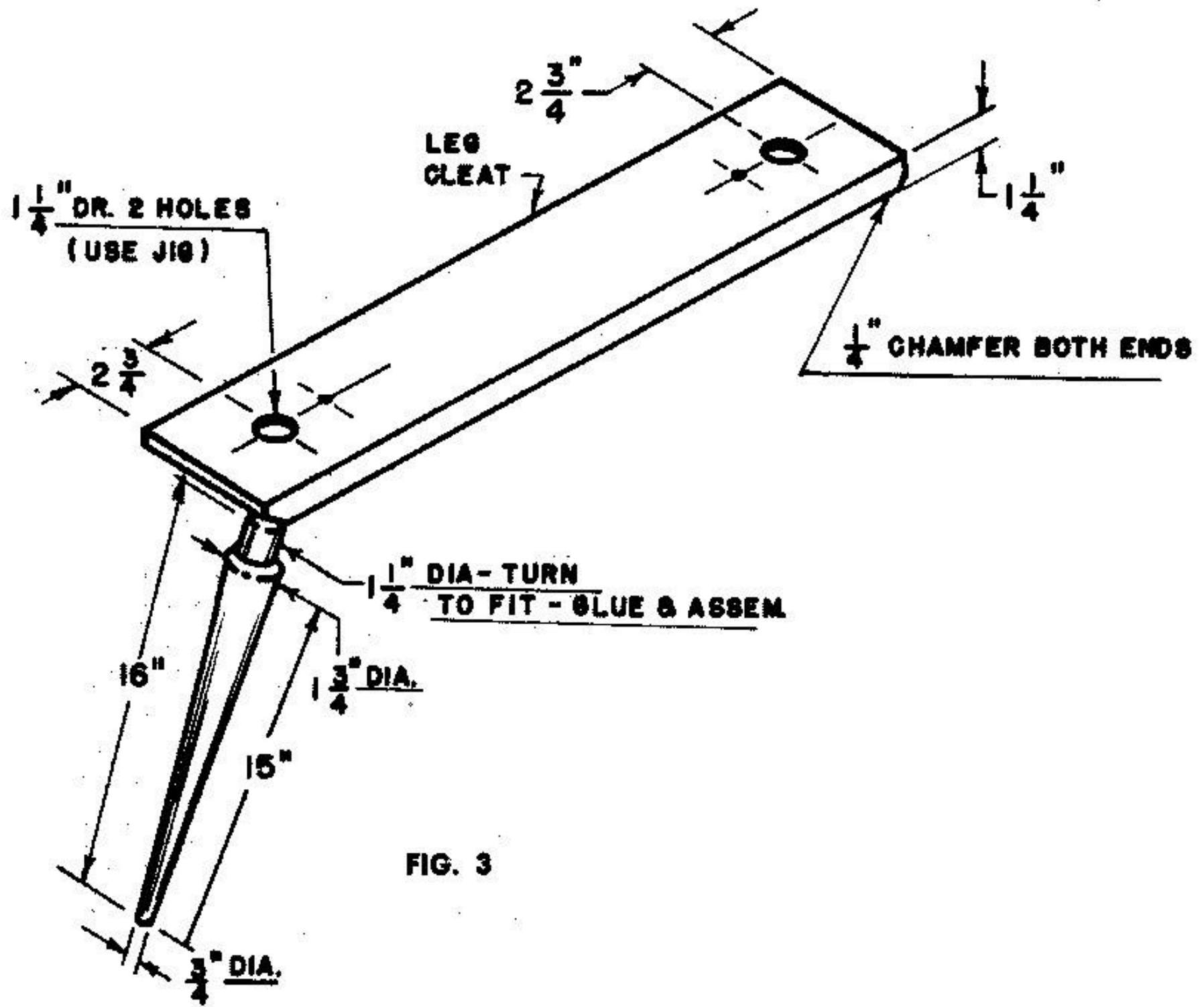

FIG. 3

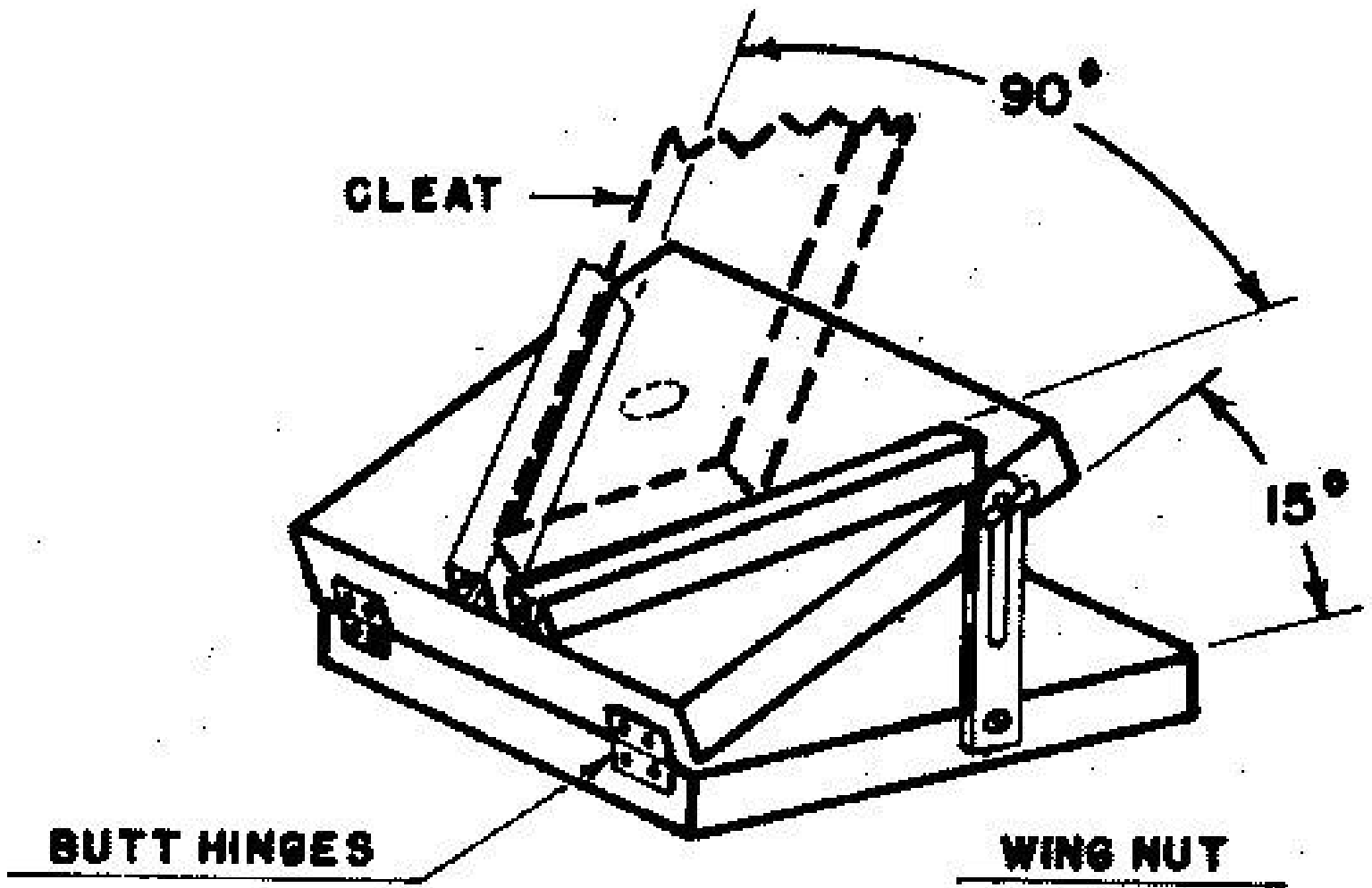

FIG. 4

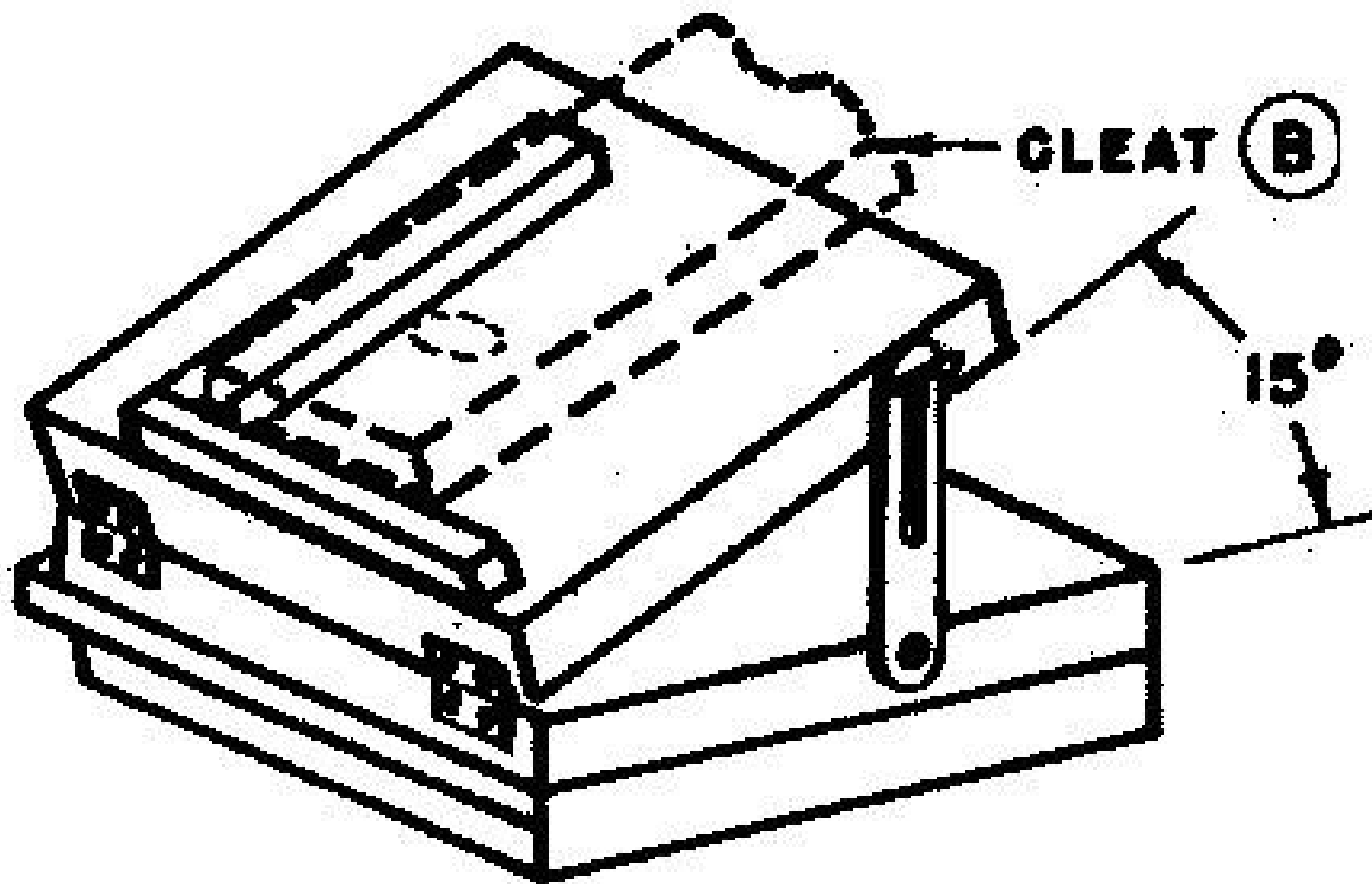

FIG. 5